

No. 846,601.

PATENTED MAR. 12, 1907.

J. S. ORAM.  
BARREL LEVELING MACHINE.

APPLICATION FILED MAY 25, 1906.

2 SHEETS—SHEET 1.

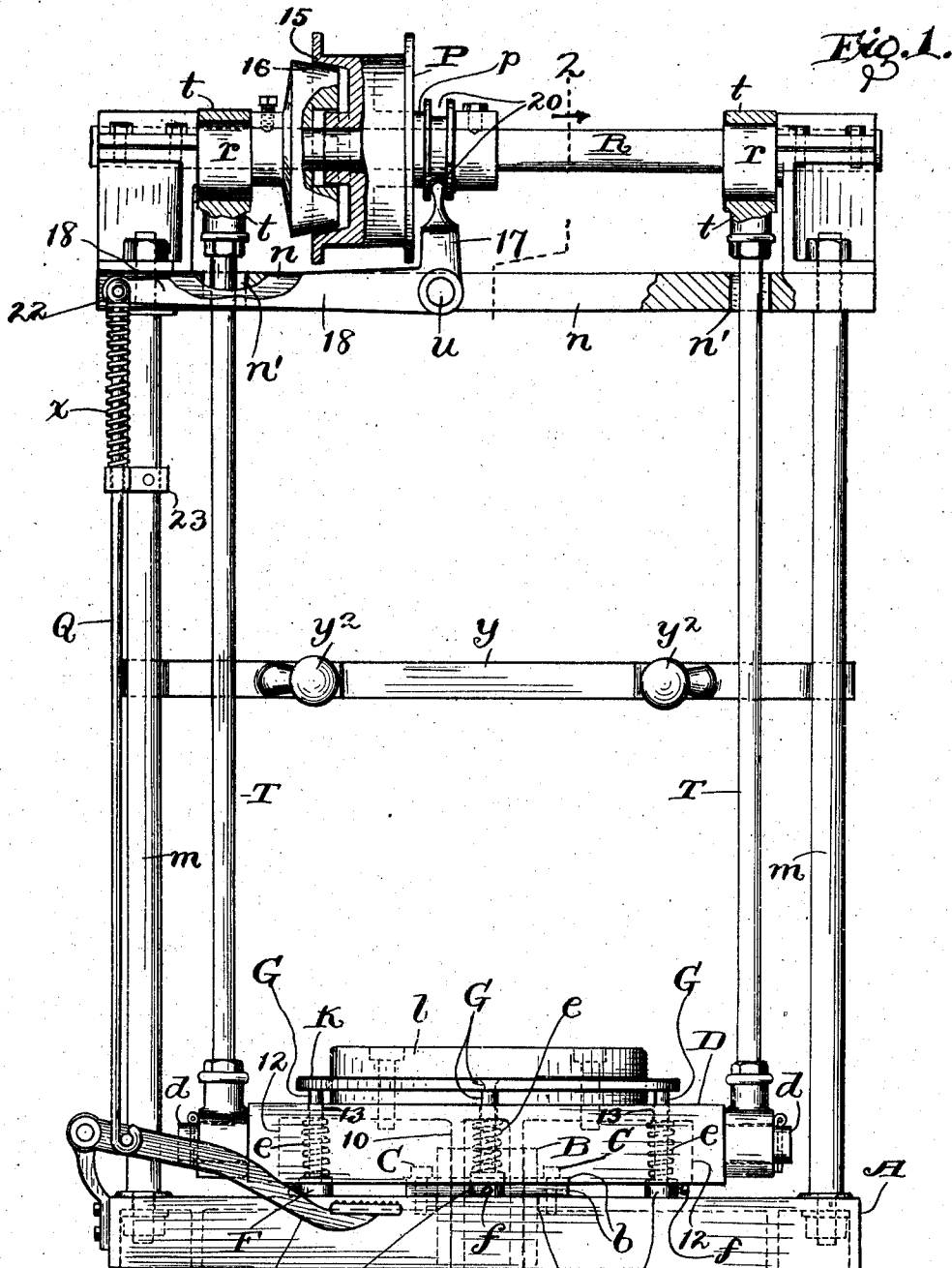

WITNESSES:  
*Daniel E. Daly.*  
*Victor C. Lynch.*

INVENTOR  
*John S. Oram*  
 BY  
*Spencer*  
 HIS ATTORNEYS

No. 846,601.

PATENTED MAR. 12, 1907.

J. S. ORAM.  
BARREL LEVELING MACHINE.  
APPLICATION FILED MAY 25, 1906.

2 SHEETS—SHEET 2.

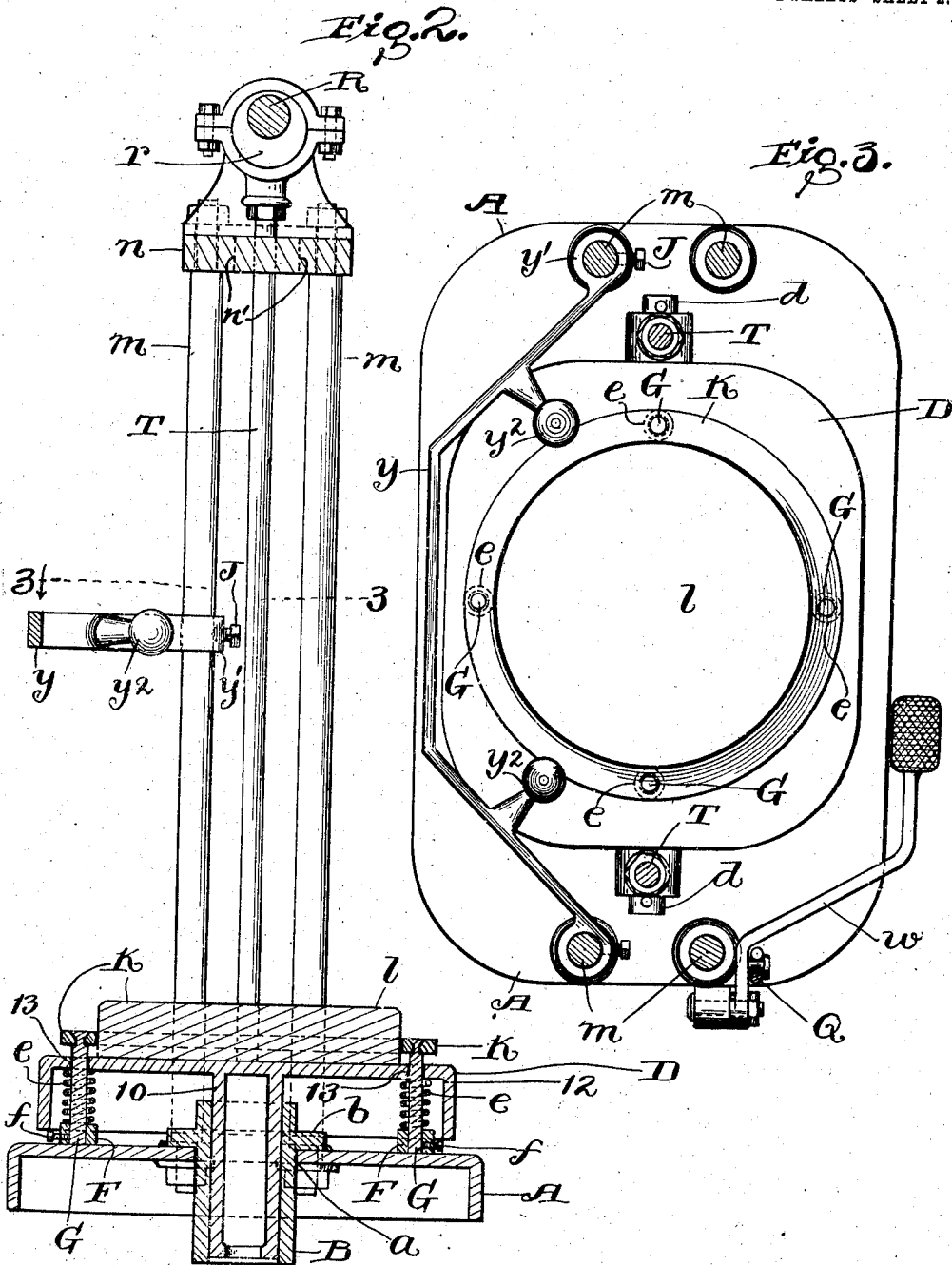

WITNESSES:

*Daniel E. Daly*  
*Victor C. Lynch*

INVENTOR

*John S. Oram*

BY

*Spencer*  
his ATTORNEYS

# UNITED STATES PATENT OFFICE.

JOHN S. ORAM, OF CLEVELAND, OHIO.

## BARREL-LEVELING MACHINE.

No. 846,601.

Specification of Letters Patent.

Patented March 12, 1907.

Application filed May 25, 1906. Serial No. 318,716.

*To all whom it may concern:*

Be it known that I, JOHN S. ORAM, a citizen of the United States of America, residing at Cleveland, in the county of Cuyahoga and State of Ohio, have invented certain new and useful Improvements in Barrel-Leveling Machines; and I hereby declare the following to be a full, clear, and exact description of the invention, such as will enable others skilled in the art to which it pertains to make and use the same.

This invention relates to improvements in barrel-leveling machines.

The primary object of this invention is to provide a simple and durable machine of the character indicated in which the staves of the barrel are rapidly leveled without mutilation of the staves.

With this object in view my invention consists more especially in a barrel-leveling machine comprising a stave-leveling ring movable up and down and adapted to support a barrel placed on end and means whereby blows are intermittently delivered upwardly against the said ring.

With the above-mentioned object in view, and to the end of realizing other advantages hereinafter appearing, this invention consists also in certain features of construction and combinations of parts hereinafter described, and pointed out in the claims.

In the accompanying drawings, Figure 1 is a front view or elevation of a barrel-leveling machine embodying my invention, and portions are broken away and in section in this figure to more clearly show the construction. Fig. 2 is a vertical section on line 2 2, Fig. 1, looking in the direction indicated by the arrow. Fig. 3 is a horizontal section on line 3 3, Fig. 2, looking downwardly.

Referring to the drawings, A represents the base of the stationary framework of the machine. The base A is provided centrally with a hole *a*. A vertically-arranged cylindrical box B extends through the hole *a*. The box B extends a suitable distance below and above the base A and is provided externally next above the said base with a horizontally-arranged laterally and outwardly projecting annular flange *b*, which rests upon the base around the hole *a*. The box B is suitably secured to the base A—as, for instance, by screws C—which are shown only in dotted lines, Fig. 1, and extend through the flange *b*

and are screwed into the base and suitably spaced circumferentially of the box.

A vertically-reciprocating blow-striking head D is arranged centrally relative to the box B and is composed, preferably, of a horizontally-arranged metal casting, which is provided at its under side and centrally with a depending tubular or hollow cylindrical stem 10, which has lateral bearing within and is adapted to slide endwise of the box B. The box B and stem 10 are instrumental in guiding the head D during its reciprocation. The head D is provided in its under side with an annular recess or chamber 12, which surrounds the upper or inner end of the stem 10 and accommodates the location of the box B during the operation of the said head. The arrangement of the parts is such that the head D in its lower position is a short distance above the base A.

A stave-leveling ring K is arranged horizontally above the head D. The ring K is movable up and down above the head D. The ring K is movable upwardly or from the head D independently of the head. The ring K is placed central relative to the head D and in their lower position arranged a suitable distance above the head. The ring K is arranged to form a seat for the lower end of an upright barrel (not shown) which is in the process of construction and has staves which are to be leveled.

Spiral springs *e* are spaced, preferably, equidistantly from and around the stem 10, being located within the chamber 12, which is large enough to accommodate the location of the springs. Each spring *e* is shown interposed between the top wall of the chamber 12 and a shoulder-forming collar F, which is secured by a set-screw *f* to and embraces the lower end of a vertically-arranged pin G, around which the said spring is coiled and which in the lower position of the head D and ring K rests upon the base A. The said pin G extends loosely through a hole 13, formed in the top wall of the chamber 12, and is secured at its upper end to the ring K, which loosely embraces and is movable up and down relative to barrel-centering means, comprising, preferably, a circular block *l*, which is mounted upon and secured to the head D. It will be observed that the block *l* constitutes a circular member instrumental in centering the barrel relative to the ring

K and is secured to the head, being mounted on the head within the ring and projecting a suitable distance above and loosely embraced by the ring. It will be observed, therefore, that the barrel to be leveled is adapted to be placed on end upon the stave-leveling ring K and in position embracing the barrel-centering block *l*; that the head D during its reciprocation strikes upwardly against the said ring from below, and blows are intermittently delivered upwardly against the lower ends of the staves required to be leveled; that the head D in its lower position engages the upper ends of the springs *e*, and that each spring *e* is interposed between a downwardly-facing surface of the head D and a shoulder of a pin or member G, depending from and attached to the ring K.

The stationary framework of my improved machine comprises also columns or standards *m*, arranged externally of the space to be occupied by the barrel to be leveled and secured to the base A. The standards *m* are tied together and braced apart at their upper ends by a cross-bar *n*. The stationary framework supports the machinery employed in transmitting power to the head D, which machinery preferably comprises a suitably-supported horizontally-arranged shaft R, located above the cross-bar *n* and operatively connected with the head D, which preferably is provided with two laterally and outwardly projecting cylindrical lugs *d*, arranged at opposite sides, respectively, of the head and in line endwise, and upright connecting-rods T are journaled at their lower ends upon the lugs *d* and terminate at their upper ends in straps *t*, which are mounted on or embrace corresponding eccentrics *r*, formed on the shaft. The rods T extend through the cross-bar *n*, which is suitably slotted, as at *n'*, to accommodate the location and operation of the said rods.

The shaft R (see Fig. 1) is provided with a suitably-driven pulley P, which is loosely mounted on the shaft, and a friction-clutch for establishing operative connection between the pulley and the shaft is provided and comprises two companion members 15 and 16. The clutch member 15 is rigid with the pulley, and consequently movable longitudinally of the shaft toward and from the companion and relative stationary clutch member 16, which is suitably fixed to the shaft. The pulley P is provided with a hub *p*, which has an external annular groove 20 engaged by the arm 17 of a bell-crank lever which is fulcrumed, as at *u*, to the cross-bar *n* and is operatively connected at the outer end of its other arm 18 by an upright rod Q with a suitably-supported foot-lever *w*. The rod Q is arranged alongside of one of the standards *m*, and a spiral spring *x* is mounted and confined on the said rod between a shoulder 22, formed on the upper end of the

rod, and a bracket 23, attached to the respective standard, which bracket is arranged a suitable distance below the said shoulder. The spring *x* acts to retain the rod Q and the connected bell-crank lever in position, holding the connected clutch member 15 out of operative engagement with the companion clutch member 16, as shown in Fig. 1.

The head D is shown arranged in its lower position, with the eccentrics *r* at the under side of the shaft. Upon the actuation of the foot-lever *w* against the action of the spring *x* the shiftable clutch member 15 is shifted toward and into operative engagement with the companion clutch member 16 to transmit motion from the pulley P to the shaft, so as to result in the reciprocation of the head D, and the arrangement of the parts is such that the head D, during each upward movement thereof, will be actuated far enough to deliver a suitable blow against the under side of the ring K, and consequently upwardly against the lower ends of the staves required to be leveled; but of course the arrangement of the parts is, furthermore, such that the barrel being operated upon shall not be lifted off the barrel-centering member *l* during the stave-leveling operation.

By the construction hereinbefore described it will be observed that the rods T are correspondingly shifted in unison during the operation of the shaft R; that the pins G hold the ring K a suitable distance above the head D, but within striking distance of the head; that the ring K is movable upwardly independently of the head D; that the ring K is driven upwardly, therefore, by a blow against the downwardly-facing surface of the ring; that the ring during its ascent does not move above the barrel-centering block *l*; that the head D frees the springs *e* during the upward movement of the head; that the said springs and the shoulders formed by the collars F form stops for limiting upward movement of the rings K independently of the head D; that of course the ring K tends to remain in its lower position by gravity, but that the head D during its descent next after delivering a blow upwardly against the ring K comes into engagement with the springs *e* and insures the prompt return of the ring K into the proper position relative to the head preparatory to the next upward movement of the head.

As already indicated, the block *l* is instrumental in centering the barrel to be leveled relative to the ring K. The means for centering the barrel relative to the ring K comprises also a bar *y*, which is arranged a suitable distance above the barrel-centering block *l*, but externally of the space to be occupied by a barrel which is to be leveled upon the ring K and terminates at the ends in sleeves *y'*, which slidably embrace adjacent standards *m*. The bar *y* is adjustable verti-

cally, being preferably secured in the desired adjustment to the connected standards *m* by suitably-applied set-screws *J*. The bar *y* is provided with two laterally and inwardly projecting members *y*<sup>2</sup>, arranged a suitable distance apart circumferentially of the space to be occupied by and in position to afford lateral bearing to a barrel to be leveled upon the ring *K*. In the operation of the machine the bar *y* is adjusted to bring the bearing-forming members *y*<sup>2</sup> thereof into position between the central portion and upper extremity of the barrel to be leveled and into such position relative to the ring *K* that when the barrel upon the leveling operation is arranged exactly vertically and central relative to the ring *K* the barrel will be in position to have lateral bearing against the members *y*<sup>2</sup>, and the attendant will, with the assistance of the upper and lower barrel-centering devices *y* and *l*, maintain the barrel in proper position relative to the ring *K* during the leveling operation.

What I claim is—

1. In a barrel-leveling machine, a stationary base provided with a vertically-arranged box extending through the base, which box is provided above the base and externally with a laterally and outwardly projecting horizontally-arranged annular flange resting upon and secured to the base; a vertically-reciprocating blow-striking head arranged in its lower position a short distance above the base and provided centrally with a depending stem which has lateral bearing in the box; means for actuating the head; a stave-leveling ring arranged to extend under the lower ends of the staves of a barrel to be operated on while in an upright position, which ring in the lower position of the head is held a suitable distance above the head but movable upwardly and within a striking distance of the head, and means for centering the barrel relative to the ring.

2. In a barrel-leveling machine, a stationary base provided with a vertically-arranged box; a vertically-reciprocating blow-striking head arranged in its lower position a suitable distance above the base and provided centrally with a depending stem which has lateral bearing in the box; means for actuating the head; a stave-leveling ring arranged to extend under the lower ends of the staves of a barrel to be operated on in an upright position, which ring in the lower position of the head is held a suitable distance above the head but within striking distance of the head and movable upwardly, and means for centering the barrel relative to the ring.

3. In a barrel-leveling machine, a stationary base; a vertically-reciprocating blow-striking head arranged in its lower position a suitable distance above the base; means for reciprocating the head; means for guiding the head during its reciprocation; a stave-

leveling ring which in the lower position of the head is held opposite and a suitable distance above the head but within striking distance of the head and movable upwardly, and means for centering the barrel relative to the ring.

4. In a barrel-leveling machine, a stationary base; an upright box arranged centrally of and extending through and supported from the base; a blow-striking head movable up and down above the base and provided centrally with a depending stem which has lateral bearing in the box; means for actuating the head; a stave-leveling ring which in the lower position of the head is held opposite and a suitable distance above the head but within striking distance of the head and movable upwardly, and means for centering the barrel relative to the ring.

5. In a barrel-leveling machine, a suitably-supported upright box; a blow-striking head movable up and down and provided with a depending stem which has lateral bearing in the box; means for actuating the head; a stave-leveling ring which in the lower position of the head is held opposite and a suitable distance above the head within striking distance above the head and movable upwardly, and means for centering the barrel relative to the ring.

6. In a barrel-leveling machine, a box; a blow-striking head provided with a stem which has bearing in the box; means for actuating the head; a stave-leveling ring arranged to overlap the ends of the stave of a barrel at one end of the barrel, which ring is held a suitable distance from but opposite the head preparatory to the ring-striking operation of the head but within striking distance of and movable from the head, and means for centering the barrel relative to the ring.

7. In a barrel-leveling machine, a blow-striking head movable up and down; means for guiding the head; means for actuating the head; a stave-leveling ring which in the lower position of the head is held opposite and a suitable distance above the head but within striking distance of the head and movable upwardly, and means for centering the barrel relative to the ring.

8. In a barrel-leveling machine, a suitably-guided movable blow-striking head; means for actuating the head; a stave-leveling ring, which in its blow-receiving position is held opposite and a suitable distance from the head but within striking distance of and movable from the head, and means for centering the barrel relative to the ring.

9. In a barrel-leveling machine, a stationary base; a blow-striking head movable up and down above the base; means for guiding the head; means for actuating the head; a stave-leveling ring which in the lower position of the head is arranged a suitable dis-

5 distance above the head but within striking distance of the head and movable upwardly; pins attached at their upper ends to the ring and depending from the ring loosely through the ring-striking head and resting on the base in the lower position of the head.

10 10. In a barrel-leveling machine, a stationary base; a suitably-guided blow-striking head movable up and down above the base; means for actuating the head; a stave-leveling ring which in the lower position of the head is arranged a suitable distance above the head but within striking distance of the head and movable upwardly, said ring having depending members extending loosely through the blow-striking head and resting on the base in the lower position of the head.

15 11. In a barrel-leveling machine, a stationary base; a suitably-guided blow-striking head movable up and down above the base; means for actuating the head; a stave-leveling ring which in the lower position of the head is arranged a suitable distance above the head but within striking distance of the head and movably upwardly, said ring having depending members extending loosely through the ring-striking head and resting on the base in the lower position of the head, which depending members are provided with shoulders arranged a suitable distance below a downwardly-facing surface of the head, and spiral springs coiled around the said depending members and interposed between the said surface of the head and the aforesaid shoulders.

20 12. In a barrel-leveling machine, a suitably-guided blow-striking head movable up and down; upright rods operatively attached to the head; means for actuating the said rods in unison, and a stave-leveling ring which in the lower position of the head is held opposite and a suitable distance above the head but within striking distance of the head and movable upwardly.

25 13. In a barrel-leveling machine, a suitably-guided movable blow-striking head; head-operating means comprising a suitably-driven shaft having eccentrics operatively connected with the head; and a stave-leveling ring held opposite and a suitable distance from the head preparatory to the striking operation of the head, which ring is movable from the head independently of the head, and means for centering the barrel relative to the ring.

30 14. In a barrel-leveling machine, a suitably-guided movable blow-striking head; means for actuating the head; a stave-leveling ring held in its blow-receiving position opposite and a suitable distance from the head preparatory to the striking operation of the head, which ring is movable from the head, and means whereby the ring is positively returned into its blow-receiving position after the striking operation of the head.

35 15. In a barrel-leveling machine, a stationary base; a suitably-guided blow-striking head movable up and down above the base having a recess or chamber in its under side; means for actuating the head; a stave-leveling ring which in the lower position of the head is arranged a suitable distance above the head but within striking distance of the head and movable upwardly, said ring having members depending into the aforesaid chamber and resting on the base in the lower position of the head.

40 16. In a barrel-leveling machine, a stave-leveling ring movable up and down and forming a seat for a barrel placed on end; means for centering the barrel relative to the ring, and means for intermittently striking upwardly against the under side of the ring.

45 17. In a barrel-leveling machine, a stave-leveling ring movable up and down and forming a seat for a barrel placed on end, and means for intermittently striking upwardly against the ring.

50 18. In a barrel-leveling machine, a stave-leveling ring arranged to support a barrel on end and movable up and down, and means for delivering blows upwardly against the ring from below the ring.

55 19. In a barrel-leveling machine, a stave-leveling ring movable up and down and suitably supported in its blow-receiving position; devices for centering the upper and lower ends of a barrel placed on end upon the ring relative to the ring, and means for delivering blows upwardly against the ring from below the ring.

60 20. In a barrel-leveling machine, a suitably-guided blow-striking head movable up and down; means for actuating the head; a movable stave-leveling ring movable up and down above the aforesaid head and forming a seat for a barrel placed on end upon the ring, which ring is arranged within striking distance of but somewhat above the head in the lower position of the head, and a circular member instrumental in centering the barrel relative to the ring and mounted on and secured to the head within the ring and projecting a suitable distance above and being loosely embraced by the ring.

65 21. In a barrel-leveling machine, a base; a suitably-guided head movable up and down above the base and in its lower position being out of contact with the base; means for actuating the head, and a ring movable up and down above the head and forming a seat for the lower end of a barrel placed on end upon the ring, which ring is held a suitable distance above but within striking distance of and movable from the head in the lower position of the head.

70 22. In a barrel-leveling machine, a suitably-guided blow-striking head; means for actuating the head; a stave-leveling ring

which in its blow-receiving position is held opposite and a suitable distance from the head but within striking distance of and movable from the head, and means for limiting the movement of the ring independently of the head upon being struck by the latter during the operation of the head.

In testimony whereof I sign the foregoing specification in the presence of two witnesses.

JOHN S. ORAM.

Witnesses:

C. H. DORER,  
B. C. BROWN.